



## EXAG – CANopen Removable End Cap

- Hollow Shaft Encoder - Ø 78 mm
- Hollow Bore: Ø 14 mm, Ø 16 mm and Ø 1 inch
- CANopen communication profile according to DS 301; Programmable according to Class 2
- Resolution up to 30 bits
- Removable End Cap for on-site installation
- ATEX, IECEx, EAC Ex and North America Class I Div. 2, Ex db IIC.

### Electrical Specifications

<b>Code:</b>	Absolute - Binary
<b>Interface:</b>	CAN CANopen protocol Transceiver according to ISO 11898; galvanically isolated by opto-couplers
<b>Resolution:</b>	Max. 14 bit (16384) revolutions Max. 16 bit (65536) steps per rev.
<b>Device Addressing:</b>	Adjustable by rotary switches in the connection cap
<b>Transmission Rate:</b>	Max. 12 MBaud
<b>Supply Voltage:</b>	10 to 30 Vdc
<b>Current Consumption:</b>	Max. 230 mA with 10 Vdc Max. 100 mA with 24 Vdc
<b>Power Consumption:</b>	Max. 2.5 watts
<b>Step Frequency LSB:</b>	800 kHz
<b>Accuracy of Division:</b>	+/- 1/2 LSB (12 bit) +/- 2 LSB (16 bit)
<b>Electrical Lifetime:</b>	> 10 <sup>5</sup> hours
<b>Electrical Protection:</b>	Reverse polarity and over-voltage-peak protection
<b>Noise Immunity:</b>	EN61000-6-2
<b>Emitted Interference:</b>	EN 61000-6-4

### Mechanical Specifications

<b>Material:</b>	Housing: Aluminum or Stainless Steel Cap: Aluminum or Stainless Steel Hollow Shaft: Stainless Steel
<b>Weight:</b>	Aluminum: ~ 1600 gr (56,44 oz) Stainless Steel: ~ 3100 gr (109,35 oz)
<b>Bearing Life:</b>	> 1,9 x 10 <sup>10</sup> revolutions at rated load
<b>Hollow Shaft Speed:</b>	6.000 rpm (max.) IP 64 3.000 rpm (max.) IP 65/66/67/68
<b>Starting Torque:</b>	≤ 0,01 Nm at 25° C (no seal) ≤ 0,03 Nm at 25° C (with seal)
<b>Rotor Mass Moment of Inertia:</b>	Face Mount B: 595 gcm <sup>2</sup> Face Mount C: 102 gcm <sup>2</sup>
<b>Hollow Shaft Loads:</b>	Axial: 60 N (13,50 lbs) max. Radial: 80 N (17,98 lbs) max.

### Environmental Specifications

<b>Operating Temp.:</b>	-40° to +70° C
<b>Storage Temp.:</b>	-40° to +70° C
<b>Shock:</b>	100 G / 11 ms
<b>Vibration:</b>	10-2000 Hz / 10 G
<b>Bump:</b>	10 G / 16 ms (1000 x 3 axis)
<b>Humidity:</b>	98 % RH without condensation
<b>Enclosure Rating:</b>	IP 64 / Nema 4 (approx.) IP 65 / Nema 5 (approx.) IP 66 / Nema 6 (approx.) IP 67 / Nema 6 (approx.) IP 68 (1hour/1 meter) / Nema 6P (approx.)

## Certifications

<b>ATEX:</b>	Certificate No.: ITS09ATEX16867X II 2 G Ex db IIC T5 Gb II 2 D Ex tb IIIC T100°C Db -40°C ≤ Ta ≤ +70°C
<b>IECEX:</b>	Certificate No.: IECEx ITS 10.0016X Ex db IIC T5 Gb, Ex tb IIIC T100°C Db -40°C ≤ Ta ≤ +70°C
<b>North America:</b>	Certificate No: LR1192-5 Class I Division 2 Groups ABCD T5, Class II Division 2 Groups FG, Class I Zone 1AEx db IIC T5 Gb, Ex db IIC T5 Gb, Zone 21 AEx tb IIIC T100°C Db, Ex tb IIIC T100°C Db, Tamb= -40 °C to +70 °C
<b>EAC Ex:</b>	НАННО «ЦСБЭ» No. EAЭC RU C-DK.AA87.B.00266/19 1Ex db IIC T5 Gb X, Ex tb IIIC T100°C Db X -40°C < T.amb < +70°C

## Interface

### Installation

The rotary encoder is connected by one, two or three cables. This depends on whether the power supply is integrated into the bus cable or connected separately. If the power supply is integrated into the bus cable, the remaining cable glands can be fitted with a plug. Any unused cable outlets must be closed using a suitably certified - proof blind plug. The threaded entries are M20x1,5.

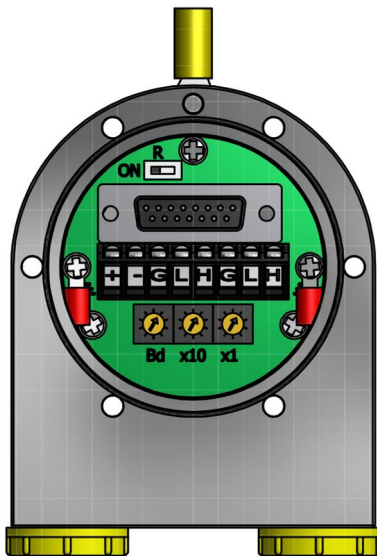

The setting of the node number is achieved by 2 turn-switches in the connection cap. Allowed addresses are between 1 and 89. Each can only be used once. **Inside the encoder, the defined address is increased by one.**

The Baud rate is set by the third rotary switch (Bd) in the cap.

The connection cap can easily be opened by removing the six screws in the cap.

The Termination Resistor is integrated into the connection cap. It must be switched on if the encoder is connected at the end or the beginning of the bus. There is separation of Bus In and Bus Out signals if the termination resistor is activated.

The EDS file is necessary for installing the encoder. The EDS file and the detailed user manual can be downloaded from our homepage: [www.scancon.dk](http://www.scancon.dk)

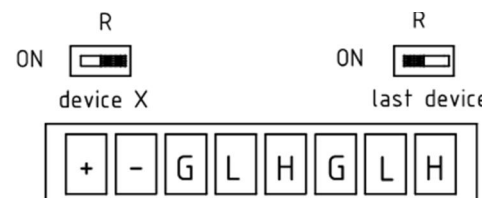

Terminal	Description
⊥	Case Ground
+	24 V Supply Voltage
-	0 V Supply Voltage
G (left)	CAN Ground (Bus in)
L (left)	CAN Low (Bus in)
H (left)	CAN High (Bus in)
G (right)	CAN Ground (Bus out)
L (right)	CAN Low (Bus out)
H (right)	CAN High (Bus out)

**The internal earth connection** (red cable shoes) is 22-16 AWG.  
*La connexion à la terre interne (Borne rouge) est en 22-16 AWG.*

**The external earth connection** (yellow cable shoe) is 12-10 AWG.

*La connexion de terre externe (Borne jaune) est en 12-10 AWG.*

**The terminal block** is intended for installation a cable with wire size:

solid 0,14 mm<sup>2</sup> – 2,5 mm<sup>2</sup>.

Stranded 0,14 mm<sup>2</sup> - 1,5 mm<sup>2</sup>

stranded with ferrule 0,25 mm<sup>2</sup> - 1,5 mm<sup>2</sup>.

The rated wire size is AWG 22-12.

*Le bornier est conçu pour une installation d'un câble à la taille du fil:*

*rigide de 0,14 mm<sup>2</sup> - 2,5 mm<sup>2</sup>*

*souple 0,14 mm<sup>2</sup> - 1,5 mm<sup>2</sup>*

*souple avec embout 0,25 mm<sup>2</sup> - 1,5 mm<sup>2</sup>.*

*La taille de fil nominale est AWG 22-12.*

## Programmable Encoder

Parameter	Comment
Operating Parameters	This parameter determines the counting direction, in which the output code increases or decreases. As an important operating parameter the code sequence (complement) can be programmed.
Resolution per Revolution	The parameter "resolution per revolution" is used to program the desired number of steps per revolution.
Total Resolution	This parameter is used to program the desired number of measuring units over the total measuring range. This value may not exceed the total physical resolution of the absolute rotary encoder. If the encoder is used in a continuous measuring application, certain rules for the setting of this parameter must be followed. These rules are outlined in the Operating Manual.
Preset Value	The preset value is the desired position value, which should be reached at a certain physical position of the axis. The position value is set to the desired process value by the parameter preset.
Limit Switch – Min. and Max.	Two position values can be programmed as limit switches. By reaching these values, one bit of the 32-bit process value is set to high.
Cam	Eight position values can be programmed as limit switches. By reaching these values bits in object 6300h Cam state register are set.

## Programmable CAN Transmission Modes

Mode	Comment
Polled Mode	By remote-transmission-request telegram the connected host calls for the current process value. The absolute rotary encoder reads the current position value, calculates eventually-set parameters and sends back the obtained process value by the same identifier.
Cyclic Mode	The absolute rotary encoder transmits cyclically – without being called by the host – the current process value. The cycle time can be programmed in milliseconds for values between 1 ms and 65536 ms.
Sync Mode	After receiving a sync telegram by the ost, the absolute rotary encoder answers with the current process value. If more than one node number (encoder) shall answer after receiving a sync telegram, the answer telegrams of the nodes will be received by the host in order of their node numbers. The programming of an offset-time is not necessary. If a node should not answer after each sync telegram on the CAN network, the parameter sync counter can be programmed to skip a certain number of sync telegrams before answering again.

## Face mounts

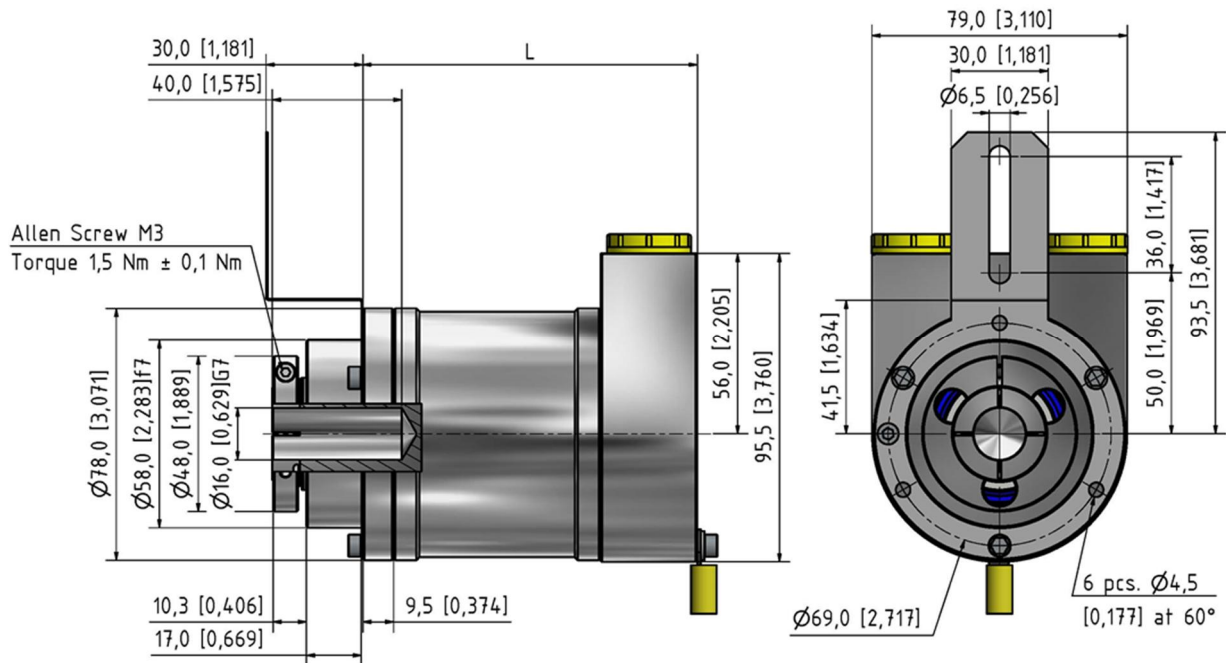

**Face Mount B**  
Clamping Flange

mm (inches)

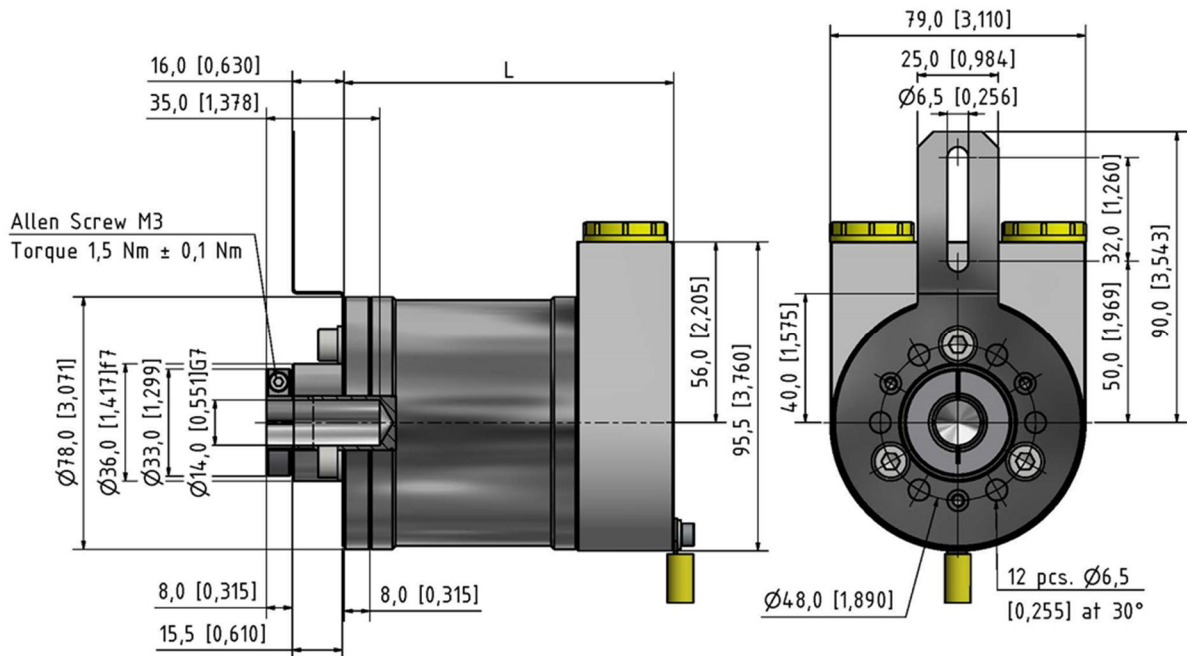

**Face Mount C**  
Clamping Flange

mm (inches)

VA/SA option only

## End Caps with Cable Outlets

Plastic screw plug is for cable outlet protection during shipping and storage.  
 Plug must be replaced by a suitably certified cable gland prior to use.

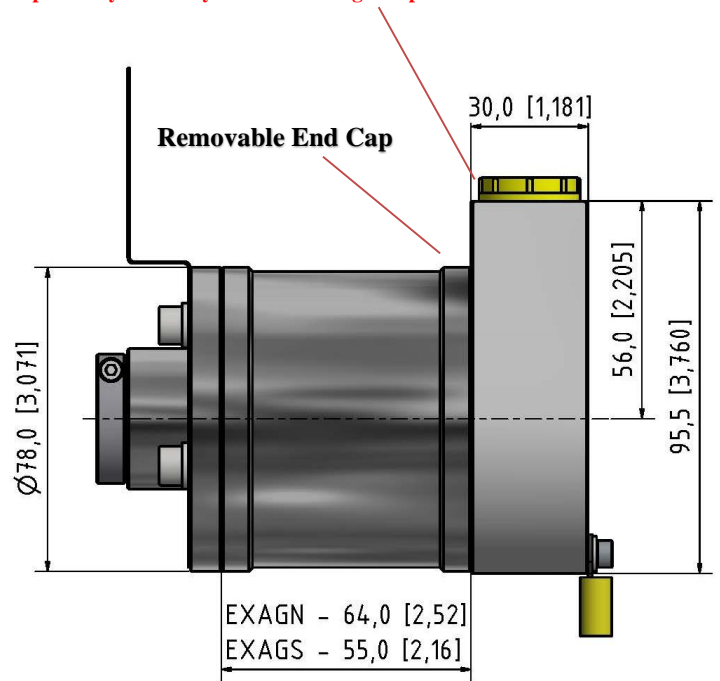
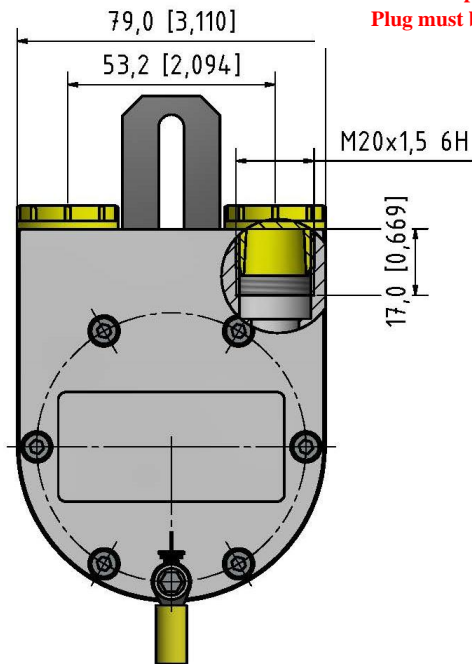

Side Standard End Cap (FZ)

mm (inches)

Plastic screw plug is for cable outlet protection during shipping and storage.  
 Plug must be replaced by a suitably certified cable gland prior to use.

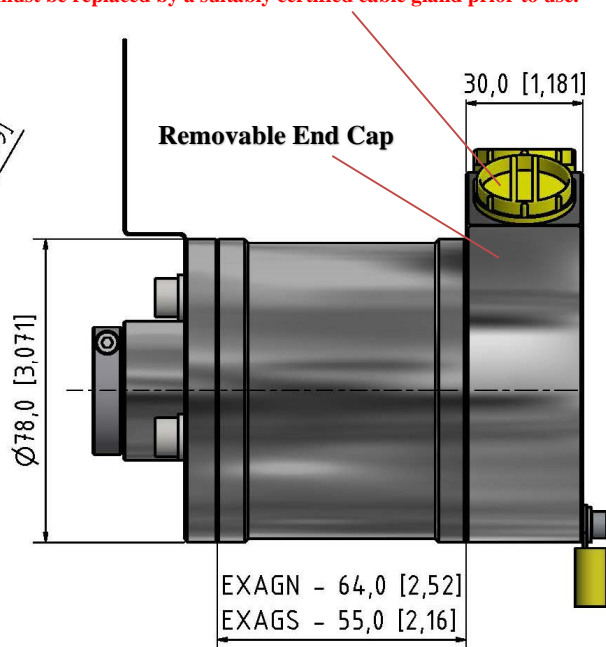
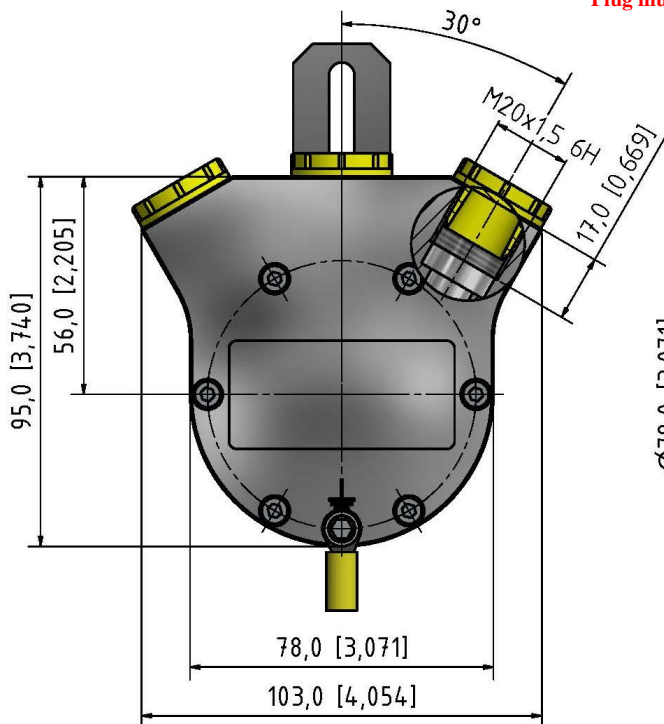

Side Triple End Cap (FE)

mm (inches)

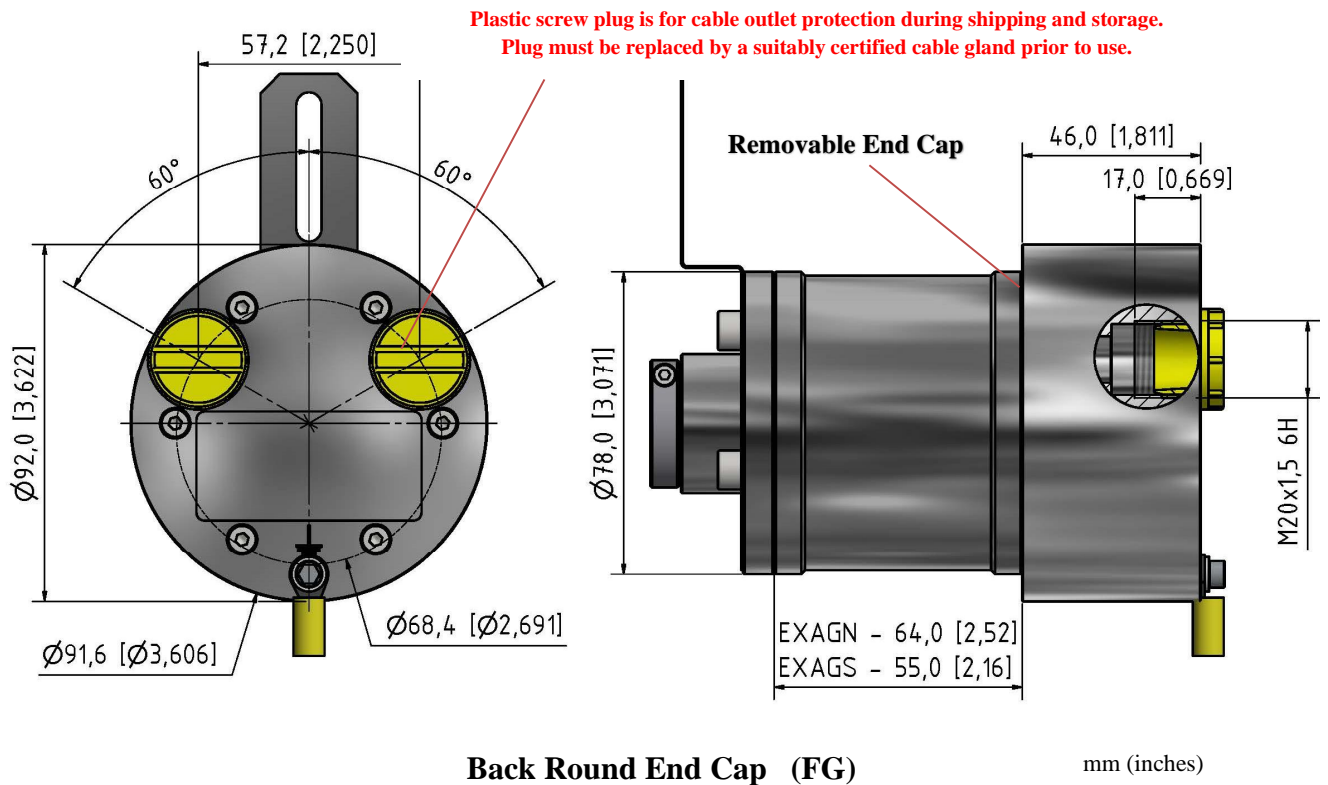

## Encoder Length

### Housing N (Table 1) (64 mm)

#### Total Encoder Length

End Cap	Clamping Flange B	Clamping Flange C
FZ	103,5 mm (4,07 in)	102 mm (4,02 in)
FE	103,5 mm (4,07 in)	102 mm (4,02 in)
FG	119,5 mm (4,70 in)	118 mm (4,65 in)

### Housing S (Table 2) (55 mm)

#### Total Encoder Length

End Cap	Clamping Flange B	Clamping Flange C
FZ	94,5 mm (3,72 in)	93 mm (3,66 in)
FE	94,5 mm (3,72 in)	93 mm (3,66 in)
FG	110,5 mm (4,35 in)	109 mm (4,29 in)

## Ordering Code

**Example: EXAGN – CAA1B – 12 – 16 – H – AL – 01 – 66 – 00 – FZ – C – S1**

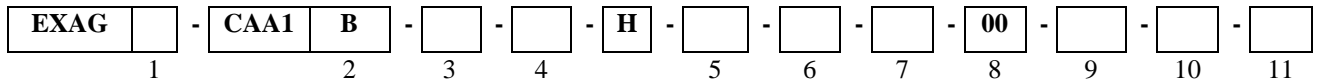

### 1. Housing

64 mm length ..... N  
 55 mm length ..... S

See Table 1 & 2

### 2. Interface

Vers. .... CAA1/  
 Code ..... Binary B

### 3. Revolution

Single Turn..... 00  
 Multiturn 12 bits (4096) ..... 12  
 Multiturn 14 bits (16384)..... 14

### 4. Steps per revolution

12 bits (4096) (0.09°).....12  
 13 bits (8192) (0.04°).....13  
 16 bits (65536) (0.005°)....16

### 5. Composition

Aluminum ..... AL  
 Stainless Steel\* ..... VA  
 Stainless Steel\*\* ..... SA

\* AISI 303  
 \*\* AISI 316

### 6. Hollow Shaft (diameter)

14 mm ..... 01  
 16 mm *Face Mount B only*..... 02  
 14 mm *Face mount B* ..... 03  
 1 inch *Face mount B only*..... 04

### 7. IP Rating

IP 64 ..... 64  
 IP 65 ..... 65  
 IP 66 ..... 66  
 IP 67 ..... 67  
 IP 68\* ..... 68

\*1 meter/1 hour

### 8. Cable

No cable..... 00

### 9. Cable Outlets

Side Standard 2 outlets ..... FZ  
 Side Triple 3 outlets..... FE  
 Back Round 2 outlets..... FG

### 10. Face mount

Clamping flange ..... B  
 Clamping flange ..... C

### 11. Accessory

Spring Coupling  
 1 hole *Flange C* p/n 80131046...S1  
 1 hole *FlangeB* p/n 80131342...S2