



EXAG – CANopen Removable End Cap

- Shaft Encoder - Ø 78 mm
- Shaft: Ø 10 mm and Ø 12 mm
- CANopen communication profile according to DS 301; Programmable according to Class 2
- Resolution up to 30 bits
- Removable End Cap for on-site modifications
- ATEX, IECEX, EAC Ex and North America Class I Div. 2, Ex db IIC.

Electrical Specifications

Code:	Absolute - Binary
Interface:	CAN CANopen protocol Transceiver according to ISO 11898; galvanically isolated by opto-couplers
Resolution:	Max. 14 bit (16384) revolutions Max. 16 bit (65536) steps per rev.
Device Addressing:	Adjustable by rotary switches in the connection cap
Transmission Rate:	Max. 1 MBaud
Supply Voltage:	10 to 30 Vdc (absolute limits) According to EN 50178
Current Consumption:	Max. 230 mA with 10 Vdc Max. 100 mA with 24 Vdc
Power Consumption:	Max. 2.5 watts
Step Frequency LSB:	800 kHz
Accuracy of Division:	+/- ½ LSB (12 bit) +/- 2 LSB (16 bit)
Electrical Lifetime:	> 10 ⁵ hours
Electrical Protection:	Reverse polarity and over-voltage-peak protection
Noise Immunity:	EN61000-6-2
Emitted Interference:	EN 61000-6-4

Mechanical Specifications

Material:	Housing: Aluminum or Stainless Steel Cap: Aluminum or Stainless Steel Shaft: Stainless Steel
Weight:	Aluminum: ~ 1600 gr (56,44 oz) Stainless Steel: ~ 3100 gr (109,35 oz)
Bearing Life:	> 1,9 x 10 ¹⁰ revolutions at rated load
Shaft Speed:	6.000 rpm (max.) IP 64 3.000 rpm (max.) IP 65/66/67/68
Starting Torque:	≤ 0,01 Nm at 25° C (no seal) ≤ 0,03 Nm at 25° C (with seal)
Rotor Mass Moment of Inertia:	42 gcm ² (5,95 x 10 ⁻⁴ oz-in-sec ²)
Shaft Loads:	Axial: 60 N (13,50 lbs) max. Radial: 80 N (17,98 lbs) max.

Environmental Specifications

Operating Temp.:	-40° to +70° C
Storage Temp.:	-40° to +70° C
Shock:	100 G / 11 ms
Vibration:	10-2000 Hz / 10 G
Bump:	10 G / 16 ms (1000 x 3 axis)
Humidity:	98 % RH without condensation
Enclosure Rating:	IP 64 / Nema 4 (approx.) IP 65 / Nema 5 (approx.) IP 66 / Nema 6 (approx.) IP 67 / Nema 6 (approx.) IP 68 (1hour/1 meter) / Nema 6P (approx.)

Certifications

ATEX:	Certificate No.: ITS09ATEX16867X II 2 G Ex db IIC T5 Gb II 2 D Ex tb IIIC T100°C Db -40°C ≤ Ta ≤ +70°C
IECEX:	Certificate No.: IECEX ITS 10.0016X Ex db IIC T5 Gb, Ex tb IIIC T100°C Db -40°C ≤ Ta ≤ +70°C
North America:	Certificate No: LR1192-5 Class I Division 2 Groups ABCD T5, Class II Division 2 Groups FG, Class I Zone 1AEx db IIC T5 Gb, Ex db IIC T5 Gb, Zone 21 AEx tb IIIC T100°C Db, Ex tb IIIC T100°C Db, Tamb= -40 °C to +70 °C
EAC Ex:	НАННО «ЦСВЭ» No. EAЭС RU C-DK.AA87.B.00266/19 1Ex db IIC T5 Gb X, Ex tb IIIC T100°C Db X -40°C < T.amb < +70°C

Interface

Installation

The rotary encoder is connected by one, two or three cables. This depends on whether the power supply is integrated into the bus cable or connected separately. If the power supply is integrated into the bus cable, the remaining cable glands can be fitted with a plug. Any unused cable outlets must be closed using a suitably certified - proof blind plug. The threaded entries are M20x1,5.

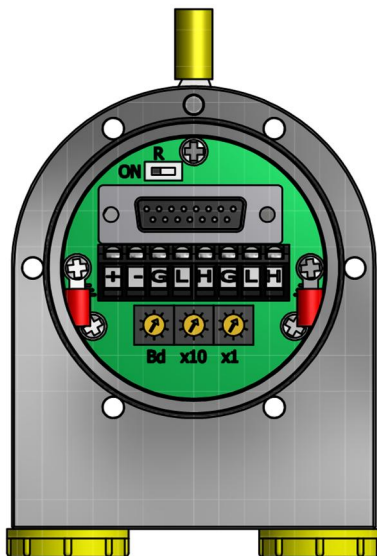

The setting of the node number is achieved by 2 turn-switches in the connection cap. Allowed addresses are between 1 and 89. Each can only be used once. **Inside the encoder, the defined address is increased by one.**

The Baud rate is set by the third rotary switch (Bd) in the cap.

The connection cap can easily be opened by removing the six screws in the cap.

The Termination Resistor is integrated into the connection cap. It must be switched on if the encoder is connected at the end or the beginning of the bus. There is separation of Bus In and Bus Out signals if the termination resistor is activated.

The EDS file is necessary for installing the encoder. The EDS file and the detailed user manual can be downloaded from our homepage: www.scancon.dk

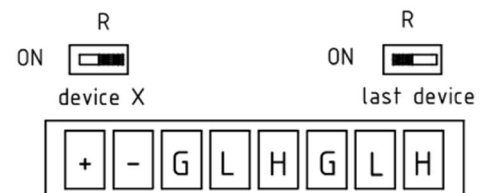

Terminal	Description
⊥	Case Ground
+	24 V Supply Voltage
-	0 V Supply Voltage
G (left)	CAN Ground (Bus in)
L (left)	CAN Low (Bus in)
H (left)	CAN High (Bus in)
G (right)	CAN Ground (Bus out)
L (right)	CAN Low (Bus out)
H (right)	CAN High (Bus out)

- **The internal earth connection** (red cable shoes) is 22-16 AWG.
La connexion à la terre interne (Borne rouge) est en 22-16 AWG.
- **The external earth connection** (yellow cable shoe) is 12-10 AWG.
La connexion de terre externe (Borne jaune) est en 12-10 AWG.
- **The terminal block** is intended for installation a cable with wire size:
 - solid 0,14 mm² – 2,5 mm².
 - Stranded 0,14 mm² - 1,5 mm²
 - stranded with ferrule 0,25 mm² - 1,5 mm².

The rated wire size is AWG 22-12.

- **Le bornier** est conçu pour une installation d'un câble à la taille du fil:
 - rigide de 0,14 mm² - 2,5 mm²
 - souple 0,14 mm² - 1,5 mm²
 - souple avec embout 0,25 mm² - 1,5 mm².

La taille de fil nominale est AWG 22-12.

Programmable Encoder

Parameter	Comment
Operating Parameters	This parameter determines the counting direction, in which the output code increases or decreases. As an important operating parameter the code sequence (complement) can be programmed.
Resolution per Revolution	The parameter "resolution per revolution" is used to program the desired number of steps per revolution.
Total Resolution	This parameter is used to program the desired number of measuring units over the total measuring range. This value may not exceed the total physical resolution of the absolute rotary encoder. If the encoder is used in a continuous measuring application, certain rules for the setting of this parameter must be followed. These rules are outlined in the Operating Manual.
Preset Value	The preset value is the desired position value, which should be reached at a certain physical position of the axis. The position value is set to the desired process value by the parameter preset.
Limit Switch – Min. and Max.	Two position values can be programmed as limit switches. By reaching these values, one bit of the 32-bit process value is set to high.
Cam	Eight position values can be programmed as limit switches. By reaching these values bits in object 6300h Cam state register are set.

Programmable CAN Transmission Modes

Mode	Comment
Polled Mode	By remote-transmission-request telegram the connected host calls for the current process value. The absolute rotary encoder reads the current position value, calculates eventually-set parameters and sends back the obtained process value by the same identifier.
Cyclic Mode	The absolute rotary encoder transmits cyclically – without being called by the host – the current process value. The cycle time can be programmed in milliseconds for values between 1 ms and 65536 ms.
Sync Mode	After receiving a sync telegram by the ost, the absolute rotary encoder answers with the current process value. If more than one node number (encoder) shall answer after receiving a sync telegram, the answer telegrams of the nodes will be received by the host in order of their node numbers. The programming of an offset-time is not necessary. If a node should not answer after each sync telegram on the CAN network, the parameter sync counter can be programmed to skip a certain number of sync telegrams before answering again.

Face mounts

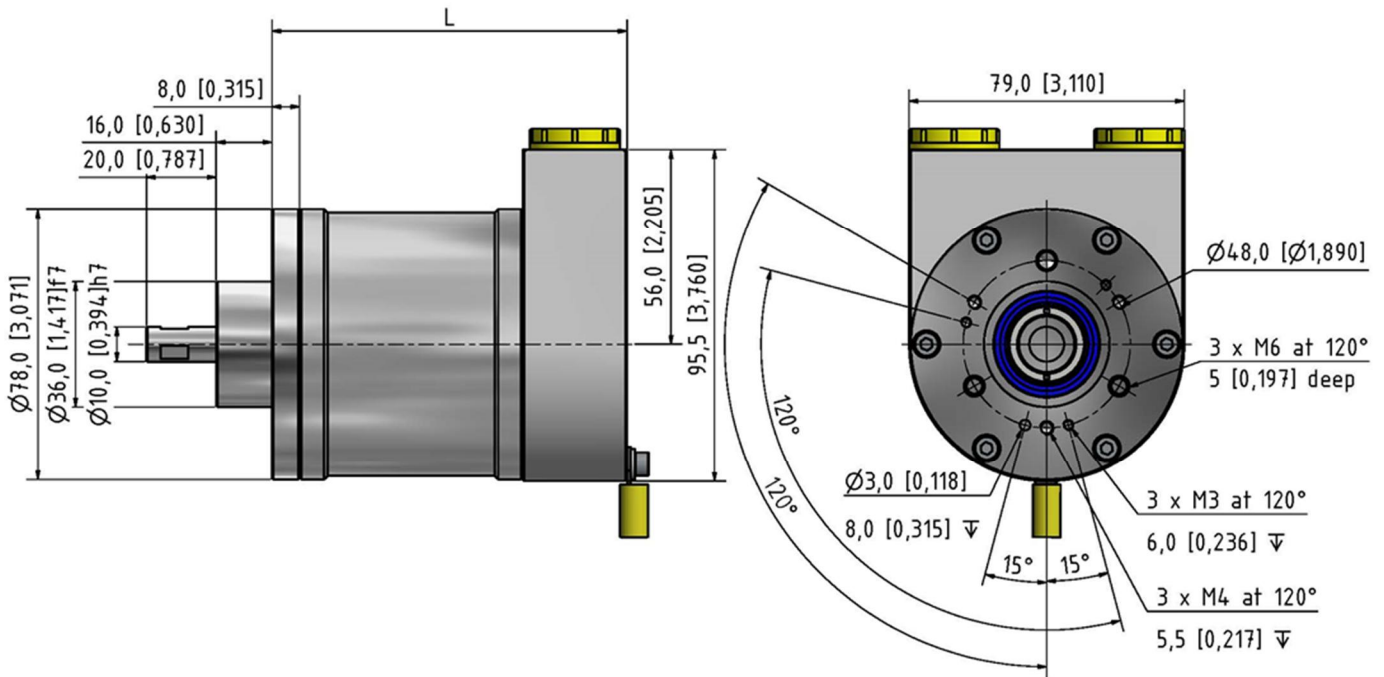

Face Mount C
Clamping Flange

mm (inches)

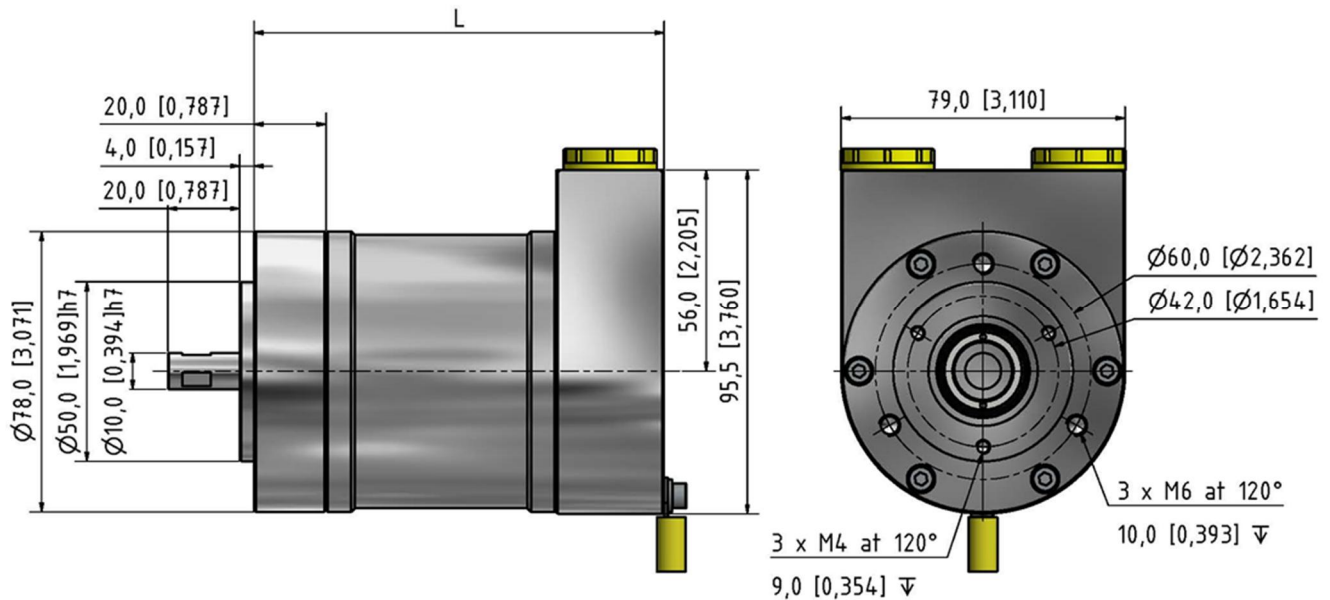

Face Mount S
Servo Flange

mm (inches)

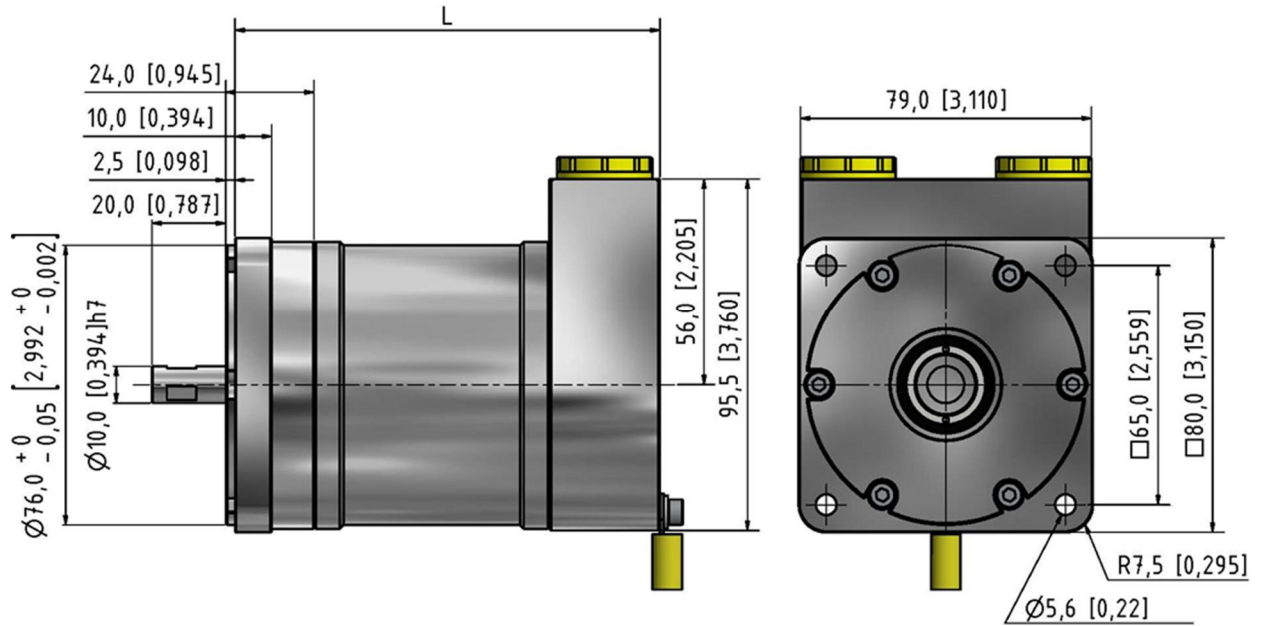

Face Mount Q
Square Flange

mm (inches)

VA/SA option only

End Caps with Cable Outlets

Plastic screw plug is for cable outlet protection during shipping and storage.
Plug must be replaced by a suitably certified cable gland prior to use.

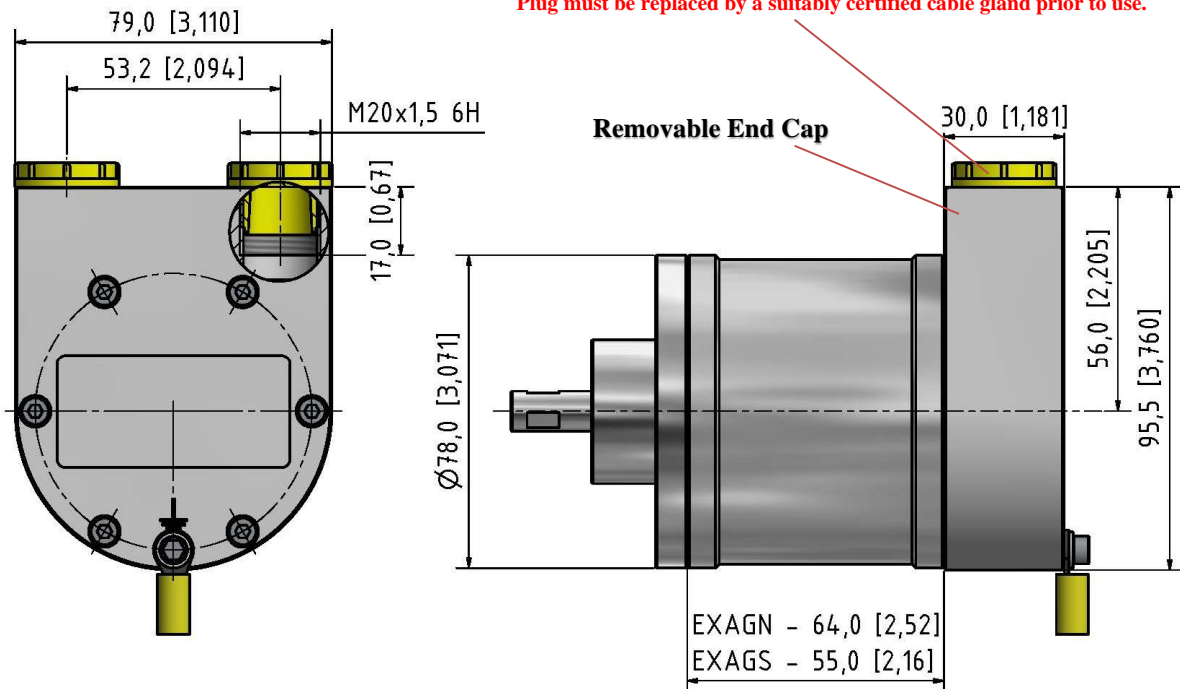

Side Standard End Cap (FZ)

mm (inches)

Plastic screw plug is for cable outlet protection during shipping and storage.
Plug must be replaced by a suitably certified cable gland prior to use.

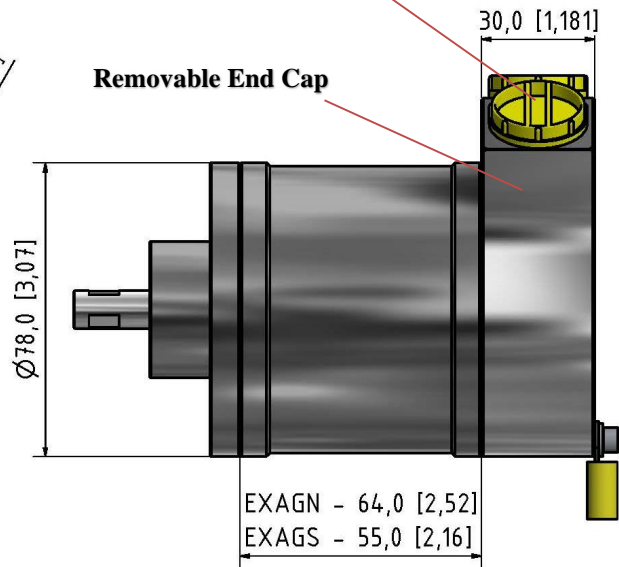
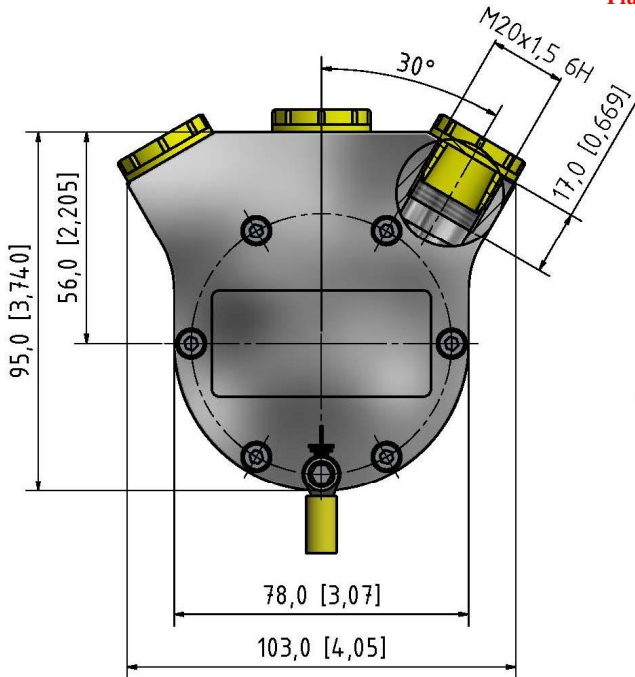

Side Triple End Cap (FE)

mm (inches)

Plastic screw plug is for cable outlet protection during shipping and storage.
Plug must be replaced by a suitably certified cable gland prior to use.

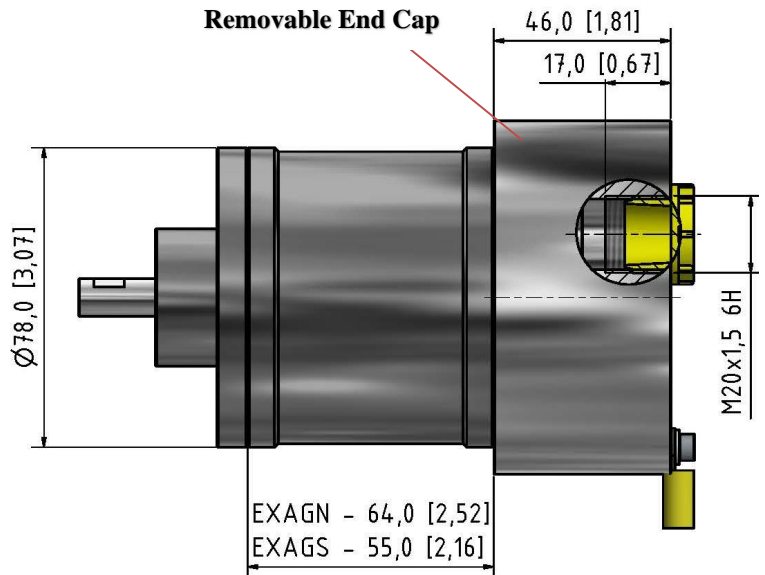
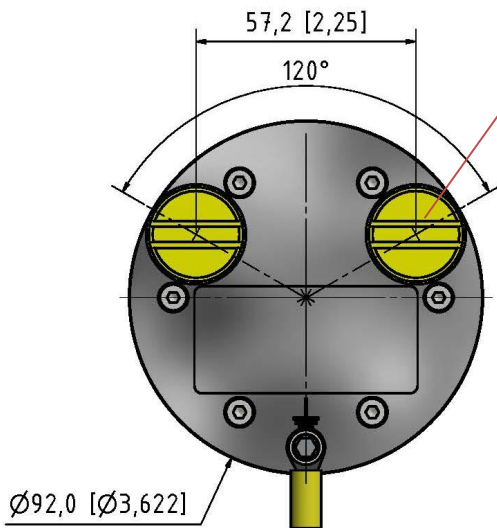

Back Round End Cap (FG)

mm (inches)

Encoder Length

Housing N (Table 1) (64 mm)

Total Encoder Length

End Cap	Face Mount		
	Clamping Flange C	Servo Flange S	Square Flange Q
FZ	102 mm (4,02 in)	114 mm (4,49 in)	115,5 mm (4,55 in)
FE	102 mm (4,02 in)	114 mm (4,49 in)	115,5 mm (4,55 in)
FG	118 mm (4,65 in)	130 mm (5,12 in)	131,5 mm (5,18 in)

End Cap + Face Mount + 64 mm = Total Encoder Length

Housing S (Table 2) (55 mm)

Total Encoder Length

End Cap	Face Mount		
	Clamping Flange C	Servo Flange S	Square Flange Q
FZ	93 mm (3,66 in)	105 mm (4,29 in)	106,5 mm (4,68 in)
FE	93 mm (3,66 in)	105 mm (4,29 in)	106,5 mm (4,68 in)
FG	109 mm (4,29 in)	121 mm (4,76 in)	122,5 mm (4,82 in)

End Cap + Face Mount + 55 mm = Total Encoder Length

Ordering Code

Example: EXAGN - CAA1B - 12 - 13 - A - AL - 01 - 66 - 00 - FZ - C - 00

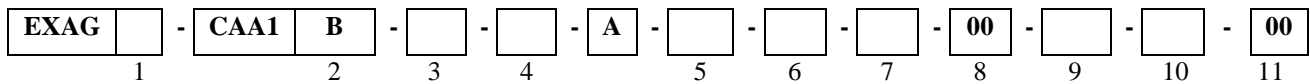

1. Housing

64 mm length N
 55 mm length S

See Table 1 & 2

2. Interface

Vers. CAA1/
 Code Binary B

3. Revolution

Single Turn..... 00
 Multiturn 12 bits (4096) 12
 Multiturn 14 bits (16384)..... 14

4. Steps per revolution

12 bits (4096) (0.09°).....12
 13 bits (8192) (0.04°).....13
 16 bits (65536) (0.005°)....16

5. Composition

Aluminum AL
 Stainless Steel* VA
 Stainless Steel** SA

* AISI 303
 ** AISI 316

6. Shaft (diameter x length)

10 mm x 20 mm 2 flats, 8mm length 01
 12 mm x 25 mm 2 flats, 8 mm length 02
 10 mm x 20 mm 1 flat, 15 mm length 03

7. IP Rating

IP 64 64
 IP 65 65
 IP 66 66
 IP 67 67
 IP 68* 68

*1 meter/1 hour

8. Cable

No cable..... 00

9. Cable Outlets

Side Standard 2 outlets FZ
 Side Triple 3 outlets..... FE
 Back Round 2 outlets..... FG

10. Flange

Clamping flange C
 Synchro flange S
 Square VA/SA option only..... Q

11. Accessory

No accessory..... 00