



Foot switch with metal enclosure

GFS 1Ö/1S RE

Material number: 1048587 (Material number old: 81201601)

Features/Options:

- With latching: ON/OFF principle
- Metal enclosure
- With protective shield
- High level of stability
- Low pedal height
- Wiring compartment

Dimensions

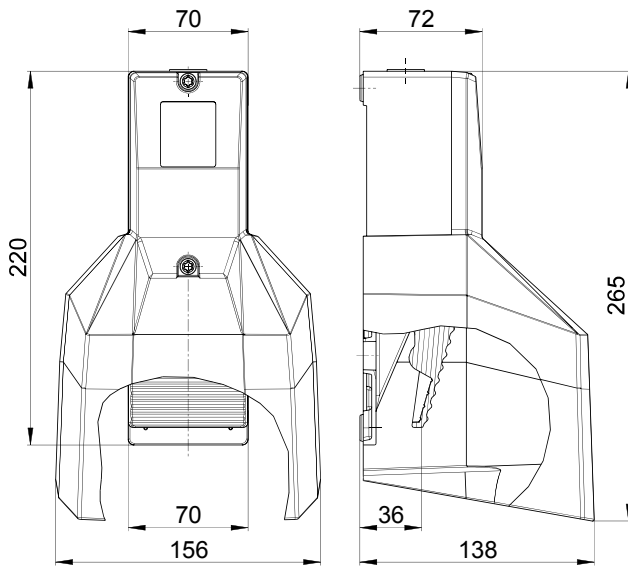

Technical data

Applied standards	EN 60947-5-1
Enclosure	aluminium die-cast, powder-coated
Pedal	thermoplastic, glass-fibre reinforced, impact resistant, self-extinguishing UL 94 V-0
Protective shield	aluminium die-cast, powder-coated
Degree of protection	IP 65 to IEC/EN 60529
Connection	screw connection terminals
Cable cross-section	max. 2.5 mm ² (incl. conductor ferrules)
Cable entry	1 x M20 x 1.5
Contact material	silver
Switching system	slow action, positive break NC contacts \ominus
Switch insert	1 x ES 60 GF RE
Switching elements	1 NC/1 NO contact with latching
Utilisation category	AC-15
Rated operating current/voltage I_e/U_e	16 A/400 VAC
Short-circuit protection	16 A gG/gN fuse
Ambient temperature	-25 °C ... +80 °C
Mechanical life	> 1 million operations
Approvals	
Weight	1280 g

Errors and omissions excepted.



Foot switch with metal enclosure

GFS 1Ö/1S RE

Material number: 1048587 (Material number old: 81201601)

Contact diagram

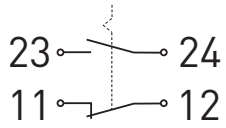

Switching diagram

