



Foot switch with metal enclosure

GFS POTI 5K 1PW

Material number: 1048739 (Material number old: 81248903)

Features/Options:

- With potentiometer 5 k Ω : Analogue output
- Metal enclosure
- With protective shield
- High level of stability
- Low pedal height
- Wiring compartment

Dimensions

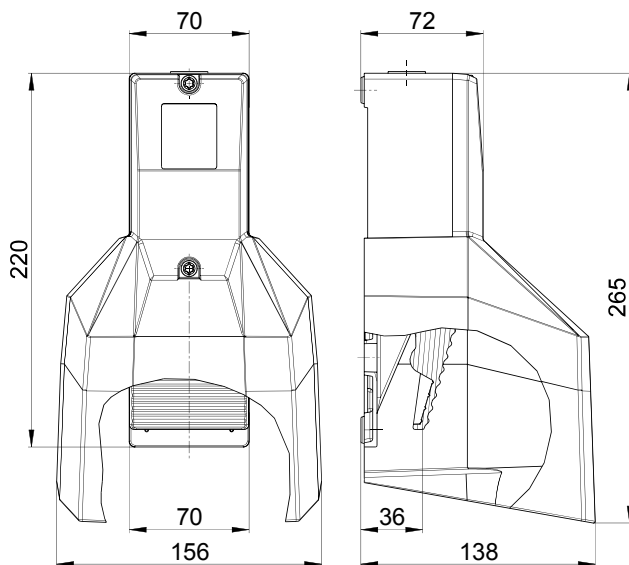

Technical data

Applied standards	EN 60947-5-1
Enclosure	aluminium die-cast, powder-coated
Pedal	thermoplastic, glass-fibre reinforced, impact resistant, self-extinguishing UL 94 V-0
Protective shield	aluminium die-cast, powder-coated
Degree of protection	IP 65 to IEC/EN 60529
Connection	soldering terminals
Cable entry	1 x M20 x 1.5
Contact material	silver, gold-plated
Switching system	potentiometer
Resistance R	50 Ω ... 5 k Ω \pm 3 %
Linearity	\pm 0.5 %
Rated operating current/voltage I_e/U_e	micro switch: 0.1 A/250 VAC; 0.1 A/24 VDC
Switching capacity	potentiometer: max. 1.5 W at 40 °C
Ambient temperature	-15 °C ... +80 °C
Mechanical life	> 1 million operations
Approvals	ERC
Note	The built-in micro switch provides for potential-free switching of the potentiometer.
Weight	1400 g

Errors and omissions excepted.



Foot switch with metal enclosure

GFS POTI 5K 1PW

Material number: 1048739 (Material number old: 81248903)

Contact diagram

