



## Foot switch with thermoplastic enclosure

### KF 2 2S/2S

Material number: 1049129 (Material number old: 87178003)

#### Features/Options:

- 2-pedal type
- Thermoplastic enclosure
- Small flat design
- Wiring compartment
- Reed contacts (2 NO contacts per pedal) for low currents from 1 mA to 1 A

#### Dimensions

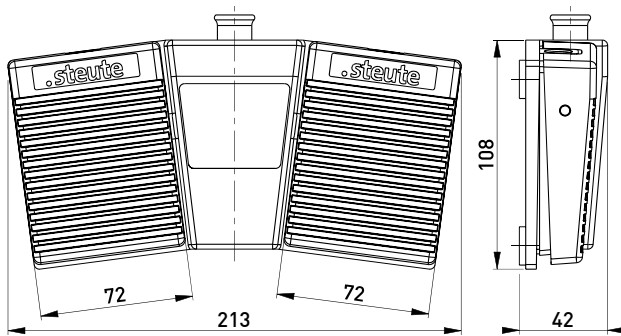

#### Technical data

Applied standards	EN 60947-5-1
Enclosure	thermoplastic, glass-fibre reinforced, impact resistant, self-extinguishing UL 94 V-0
Pedal	thermoplastic, glass-fibre reinforced, impact resistant, self-extinguishing UL 94 V-0
Degree of protection	IP 65 to IEC/EN 60529
Connection	wiring compartment, cable gland M12 x 1.5
Switching system	reed contacts
Switching elements	2 NO contacts per pedal
Switching voltage	12 ... 250 VAC/DC
Switch-on current	max. 1 A
Switch-on power	max. 30 VA
Ambient temperature	-10 °C ... +60 °C
Mechanical life	> 1 million operations
Approvals	
Weight	466 g

#### Contact diagram

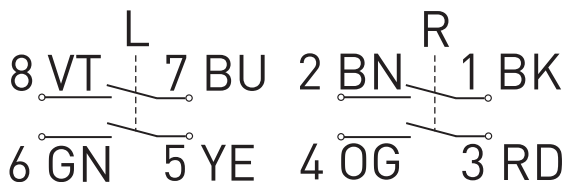

Errors and omissions excepted.